

D&E TIGHT COVERTM DUCTILE IRON TREATMENT LADLES

**SIZES UP TO
20,000-LBS.**

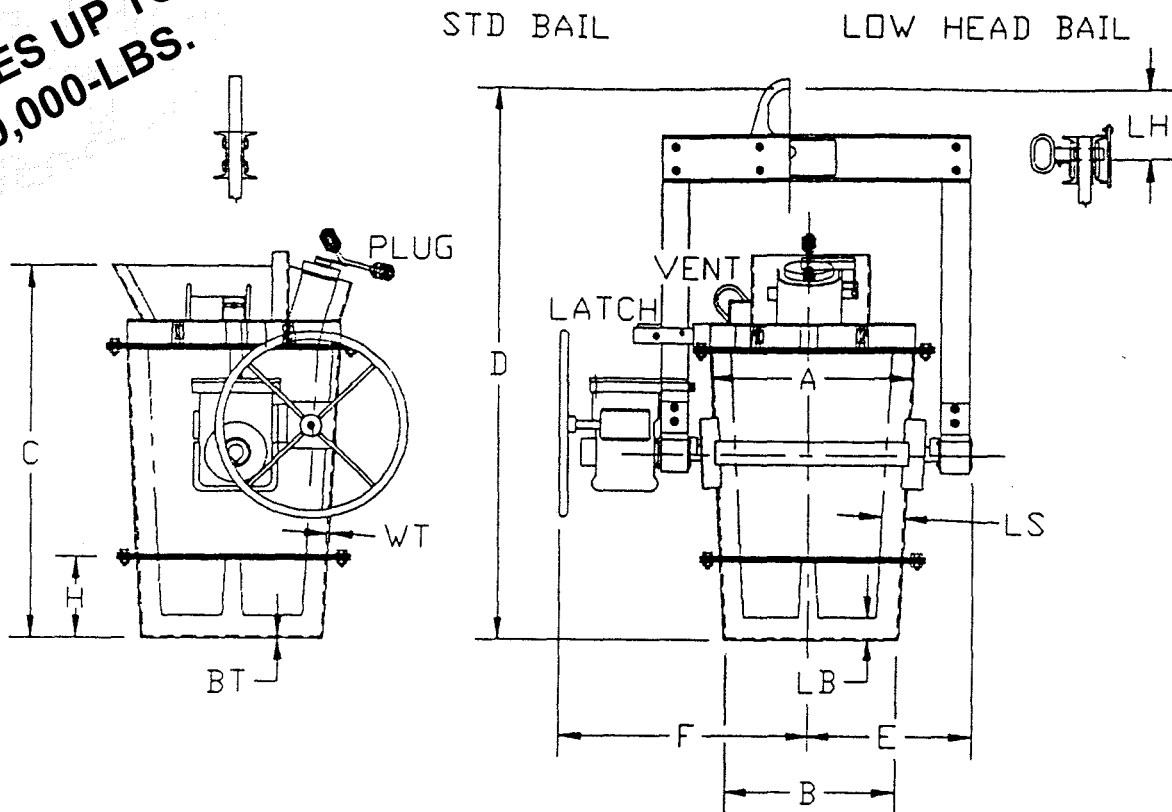

Ladle lining forms and spare ladle bottoms are some of the accessories that help control maintenance costs and down time for D&E process ladles. Other options include motorized gear tilt and cradles that hold ladles for pouring. See catalog page 10-12 for a complete description of D&E Ladle innovations and accessories.

Model No.	Iron Capacity	A ID	B ID	C	D	LH*	E	F	H	LB	LS	BT	WT
LO15-195-3050	600	19.5	17.5	36.0	56.8	8.0	16.0	28.3	8.3	3.0	2.5	0.25	0.19
LO15-220-3050	1000	22.0	19.0	40.3	61.3	8.0	17.0	29.3	9.0	3.0	2.5	0.25	0.19
LO15-240-3550	1500	24.0	20.3	45.8	68.8	8.9	18.3	30.5	10.0	3.0	2.5	0.25	0.19
LO15-260-4060	2000	26.0	22.0	47.5	72.5	8.9	20.3	34.3	10.5	3.0	2.5	0.25	0.19
LO15-300-4060	3000	30.0	25.3	53.8	81.8	8.9	23.0	36.3	12.0	4.0	3.0	0.38	0.19
LO15-340-50D4	4000	34.0	29.3	56.8	84.8	8.9	25.0	38.5	13.0	4.0	3.5	0.38	0.25
LO15-380-50D4	6000	38.0	32.8	63.8	91.0	15.8	26.8	40.3	14.0	4.0	3.5	0.38	0.25
LO15-420-60D4	8000	42.0	36.0	71.0	103.0	15.8	31.0	48.0	16.0	5.0	4.0	0.38	0.31
LO15-455-70D6	10000	45.5	39.0	76.0	117.0	N/A	32.5	50.0	18.0	5.0	4.5	0.50	0.31
LO15-457-70D6	12000	47.5	41.0	82.0	124.0	N/A	33.5	51.0	18.0	5.0	4.5	0.50	0.38

*Height "D" is reduced by "LH" with Low Headroom Bail option.

NOTE: Capacities are in pounds. Dimensions are in inches and are subject to change.